Tripod Turnstile

Use Manual

Table of Contents

1.Product Brief.....	2
1.1 Description.....	2
1.2 Main functions and features.....	2
1.3 The main technical parameters 1.....	3
2.Device Dimensions	3
3.Installation and commissioning of three devices	4
4 Device Instructions	4
5 Routine Maintenance	5
Appendix I System Menu Settings Description	5
Appendix II tripod turnstile menu settings for use	8
Appendix III Troubleshooting and Analysis.....	9
Appendix IV tripod turnstile wiring diagram.....	11

1.Product Brief

1.1 Description

The tripod turnstile is my company's own development, development and production of intelligent channel management equipment.

By configuring different read-write device, you can complete the channel intelligent traffic control and management.

The entire product shape with stainless steel plate stamping, Nice shape, rust-proof, durable.And the system uses a standard external electrical interface, Can easily integrated with reader devices such as bar code cards, ID cards, IC card on the equipment.To provide for the orderly and civilized communication access to staff, and prevent illegal personnel access.Meanwhile, in order to meet the requirements of the fire channel,In case of emergency power off,channel keeps open,organize evacuations.

1.2 Main functions and features

- 1)using an electromagnet, positioning arm lock, so that the gates at zero lock, unlock more accurate and reliable.
- 2)The whole system running smoothly, low noise, no mechanical impact
- 3)has a power-on self-test function, automatic recovery in the locked state.
- 4)has a variety of operating modes to choose from, you can two-way card reader, but also while reader, forbidden line in another direction, while reader, free movement in the other direction, and the gates operating mode can be set by the board menu fixed.
- 5)Out power,the rod automatically go down.With power,should raise rod by hands
- 6)external electrical interface with a unified standard, with a variety of read-write device mounted, easy system integration, and enables remote control and management by managing computer.
- 7)The number of traffic can automatically access the direction of statistics, and an intuitive LED (optional) approach is presented to managers
- 8)With a clear indication of the direction of traffic to pass through an intuitive LED indication who can pass or closed to traffic.
- 9)has a card reader with memory and without memory function, and the user can be carried out by the board to set the keyboard to suit your needs.
- 10) with automatic reset function. When the reader, when the passage of time are not within the specified traffic, the system will automatically cancel the access permissions for those who pass,

the passage of time and the limits set by managers themselves.

1.3 The main technical parameters

- 1) Power supply voltage: AC220V ± 10V, 50Hz
- 2) Working temperature: -15 °C ~ 60 °C
- 3) Relative humidity: less than 95%, non-condensing
- 4) The maximum channel width 600mm
- 5) Pass speed: 40 / min (IC card)
- 6) work: 24V / 30W DC electromagnet
- 7) Input Interface: + 12V level signal or pulse width > DC12V pulse signal of 100ms, Drive current > 10mA
- 8) Communication interface: RS485 electrical standards, communication distance: ≤1200 m

2. Device Dimensions

2.1 Equipment shape and size

Tripod turnstile of varieties and specifications, can be divided to 7 categories according to the chassis appearance: Bridge rounded tripod turnstile, bridge bevel tripod turnstile, bridge butterfly tripod turnstile, bridge arc tripod turnstile, bridge octagonal tripod turnstile, vertical tripod turnstile and dual vertical column tripod turnstile. Its shape and size shown below

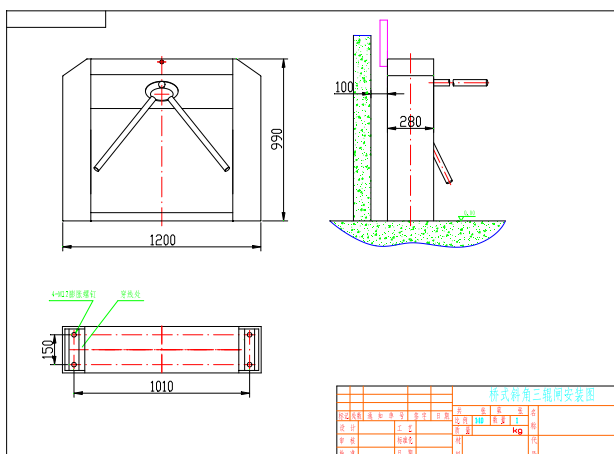

Bridge Type Tripod Turnstile
1200*280*1000mm

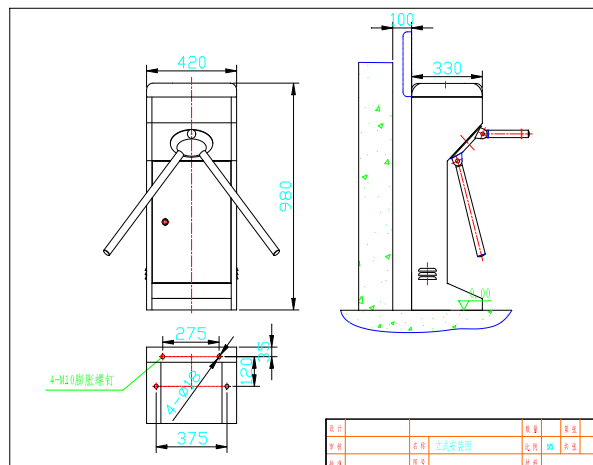

Vertical Type Tripod Turnstile
420*330*980mm

3. Installation and commissioning of three devices

3.1 Devices Installation

- 1) an inventory of parts according to the packing list
 - 2) Depending on the system components, the use of the site as well as the choice of models, to determine the installation position of each of the gates.
 - 3) installation requirements as shown below, to determine the mounting holes, four M12 bolts embedded anchor bolts or four M12 at the location of the installation.
 - 4) The strong electric cables and electronic cables were used 3/4 "PVC pipe to put on line, buried with cement to the appropriate location
-
-



1. Buried PVC pipe line depth should be more than 60mm, height above the ground shall be greater than 50mm, And exit of pipe is back to the bend, prevent water goes into pipes

- 5) Open the cabinet door, the bolt holes in the base bolt, tighten the nut
 - 6) According to the system wiring diagram, connect the power cable, control cable and connect the main control panel gates, and connect ground line
-



1) All of the above operations, shall operate in case of power failure, and should ensure the protection of earth system correctly connected, connected securely.

2) When the choice of equipment used outdoors, it should 100mm ~ 200mm high cement mounting platform installed on the device at the puzzle, so that moisture barrier; while at the top of the device should be installed sun sheds and other facilities from the storm, prohibited device placed directly outdoor environments;

4 Device Instructions

- 4.1 Ensure that the device is working properly, can be put into use
- 4.2 During the passage by reading and writing, before the passage indicator does not turn green, non-crowded, rely on, push the brake lever, so as not to affect the normal operation of equipment.
- 4.3 device when not in use, is strictly prohibited sit brake lever with a beat in order to avoid unnecessary damage to gates

4.4 is not recommended to use the device directly in the open air, under wet or corrosive environments, so as to avoid rain, moisture or corrosive impact equipment life (if used outdoors, must be added, such as the sun sheds rain facilities)

4.5 during the passage, the passage by just gently push the brake lever, rather than a strong push brake lever movement in the passage process.



-
- 1) Do not use the machine when there is thunder and lightning, to prevent damage to the gates
 - 2) Should ensure reliable protection system connected to prevent damage to the safety of other accidents from happening

5 Routine Maintenance

5.1. This equipment is stainless steel shell, subject to usual gentle scrub fabric appearance, keep it clean and smooth, do not scrub the exterior with hard objects, so as not to affect the appearance of scratches, while the rinse water should be prohibited in order to avoid short-circuiting the electronic control system, and damage equipment.

5.2. connections regularly check various moving parts of equipment, such as found loose nuts, bolts and other fasteners should be tightened in order to avoid long-running gates cause malfunction.

5.3. regular inspection system protection to the situation at the connection, ensure reliable access.

5.4. point connectors and wiring to connect the line regularly checked to ensure reliable connection.

Appendix I System Menu Settings Description

1. basic parameter

- 1) Power supply voltage: AC220V 50Hz;
- 2) Working environment: -15 °C ~ 60 °C;
- 3) The maximum channel width: 600mm;
- 4) Input Interface: + 12V level signal or pulse width > DC12V pulse signal of 100ms, the drive current > 10mA;
- 5) Communication interface: RS485 electrical standards;
- 6) Communication Distance: 1200 meters;
- 7) management of computer equipment with remote control.

2. brake lever assembly (see Figure 1)

- 1) The brake lever placed in an aluminum disk to install slot;
- 2) the pin in an aluminum pan pin hole;
- 3) the pin into place, then tighten the screws.

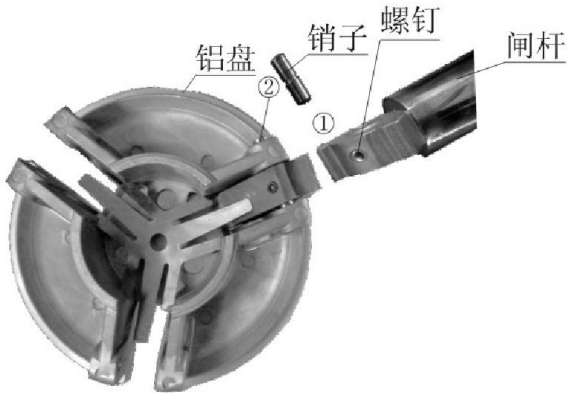

Figure 1

3.movement chart (see Figure 2)

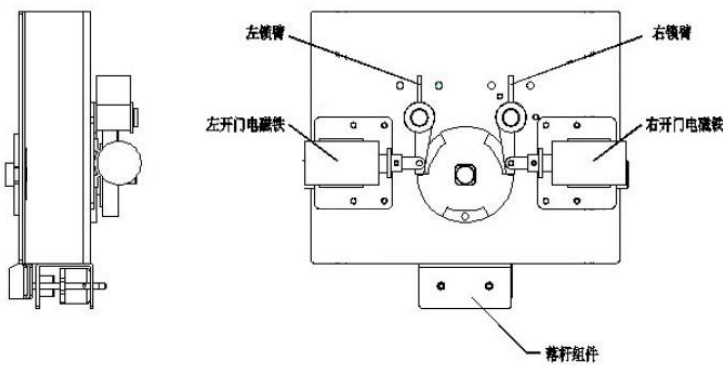

Figure 2

Free passage in one direction: Adjustment unidirectional machine screws, lock positioning arm, you can make a one-way gates free passage.

4.debugging preparations before

- 1) Electric tripod turnstile device wiring diagram 1, 1 site map movement until commissioning of electric equipment of a three roller gates, and carefully read the "electric tripod turnstile menu settings for use";
- 2) about the definition: the face of three roller gates, three roller gates of the left hand that is on the left, the right hand side to the right side;
- 3) Input Interface: + 12V level signal or pulse width > DC12V pulse signal of 100ms, the drive

current > 10mA;

4) Check the wiring is consistent with the wiring diagram, check all plugs are loose; make sure there is no mechanical parts stuck, flexible operation, protected equipment must be grounded, for recognizing the power to debug and correct.

5) three roller gates wiring diagram, according to the identity of terminal block and connect the power gate signal;



5. System Functional Test

1) left gate pass: When the left gate signal, three roller gates will automatically unlock, directions Turns green traffic signs, pedestrians waiting to enter; after pushing back when the pedestrian access to the rotation angle of three roller gates, the reset photoelectric switch and turn the reset effective photoelectric switch, the system automatically locking action, direction indicator turns red forbidden line signs. The maximum time for each pass 10 seconds (this parameter is set by the user, the following are 10S, for example), After the passage of time than the set no such access, the device will automatically reset;

2) the right of the gate passage: When the right of the gate signal, the motor will automatically run in the unlocked state, direction indicator turns green traffic signs, pedestrians waiting to enter; three roller gates when promoting pedestrian access to the rotation after a certain angle, the reset photoelectric switch and turn the reset effective photoelectric switch, the system automatically locking action; direction indicator turns red stop sign;

The maximum time for each pass 10 seconds (this parameter is set by the user), when traffic exceeds the set time no such access, the device will automatically reset;

3) Off lever function test: turn off the power, brake lever falls; after power electromagnet produces a magnetic, you can manually liter rod;

Lift rod: first force bar and then lift the rod can be stuck to a horizontal position;

6. Note

1) without permission, do not add peripherals on the device and ensure reliable system ground to ensure the safety devices work reliably;

2) When the device is used outdoors, it should 100mm ~ 200mm high cement platform installed on the device is installed at the puzzle, so that moisture barrier; while at the top of the device should be installed, such as the sun sheds rain facilities, prohibited device placed directly outdoor environments;

3) Do not use this equipment when there is lightning, to prevent damage to gates;

4) If the above guidelines is unknown, please contact the supplier.

Appendix II tripod turnstile menu settings for use

1. General description of

1.1. The display refers to the main board from left to right shows three LED digital tube;

1.2. The main control panel's three buttons in the same row, from left to right are three buttons SET button, INC key, DEC key, SET key is used to enter and exit the menu, or enter and exit the function setting; INC key parameters need to be set for the conduct plus 1; DEC keys are used to set the parameters that need to be minus 1; When the need to adjust the menu, press the SET button, then will display the word "P00", press INC or DEC key to add or subtract to the menu item to be adjusted after the OK, you can make adjustments; After adjustment press INC or DEC key to return to the P00, press the SET button to return to operational status: RUN.

Example: If you want to set the maximum amount of time each person through the channel for six seconds

Step 1: Press the SET button, then will display the word "P00"

Step 2: Press the INC or DEC key until the words "P03"

Step 3: Press the SET button, then will show "010" word (which is the default setting 10 seconds)

Step 4: Press the INC or DEC key until the display "006"

Step 5: Press the SET button, then will return back to the words "P03"

Step 6: Press the INC or DEC key until the words "P00"

Step 7: Press the SET button, then will return to the word "RUN", you can work properly.

2. Set to enter and exit the menu

2.1. Go to the menu: press the SET button to hear a "beep" is heard, release the SET button, then the display shows the word "P00", that has entered the menu setting state, then the available keys INC and DEC keys to Select the setting function function number; press INC, plus a function number, press the DEC key function number minus one; there were 15 kinds of function settings are:

P00: Quit menu settings function, when there is P00, press the SET button to exit the menu settings; use the INC and DEC keys to select the setup parameters;

P01: working status of the device setting function, the device has three kinds of working conditions,

P01 = 0: controlled access to all required reader; P01 = 1: Left to enter controlled, need to reader;

P01 = 2: Right to enter controlled, need to reader;

P02: locking motor delay the return to zero after the equipment;

P03: Setting everyone longest transit time through the channel;

P15: System Restore Defaults, when the display P15 press the SET button to display P-2, then press INC system Restore Defaults

2.2.Exit menu settings: Press the C key or the DEL key word when there is P00, press the SET button to exit the menu settings.

Appendix III Troubleshooting and Analysis

Basic concept:

A.Unlock photoelectric switch: The light barrier optocoupler



General G1 to 12V output pulse signal; the red indicator lights up when the output voltage.

B. the electromagnet: DC24V DC solenoids, normal

Work overload current space-time around 300mA, the load current is less than 1A.

1. the direction of the electric light no display, and the reader can not work.

The failure was mainly a problem with the machine's power system, whether the device should be carefully checked the master controller 5A fuse is damaged, the connector is loose, the transformer output is normal black 12V, blue 18V, the output of the power cord is disconnected etc.

2. in the course of occasional phenomenon off the bar

The main cause of the fault has the following two reasons:

2.1.drop in the fixed pole electromagnet two M5 hex screw loose. Its Remedy:

- 1) with a key to open the case to the cover;
- 2) Loosen off the pole electromagnet fixed two M5 hex screw;
- 3) off the pole solenoid bracket gently moves up a little;
- 4) Tightening off lever inside the solenoid two M5 hex screw;

5) electrical checks on whether to exclude faults, otherwise press repeat 2) to 4) of the method, until troubleshooting;

2.2.aluminum disk inside the shrapnel stretch inadequate; or because of wear rods and aluminum plate bracket serious

The failure shall promptly notify our service department or an authorized service agency for a replacement.

3.power-up or during use, the brake lever can not be reliably locked

The failure was mainly caused by the electromagnet off the pole is damaged or broken, loose wiring situation, or the figure shrapnel fracture.

4.read a card, you can continuously by people

The failure was mainly caused by the following reasons:

1) solenoid failure or reset tension spring tension is not enough, resulting in rapid and reliable positioning arm can not reset the lock.

2) Limit board is damaged

3) Access to open the door to set the delay time is too long

5.not the normal reader

The failure was mainly reader devices to access the wiring between the plates are loose or damaged card reader device, re-test after replacing the card reader device.

6.normal reader, directions to allow access state, but is impassable

The fault is mainly caused by the following reasons:

1) Non-voltage solenoid, solenoid two lines are directly connected to the 24V and GND to see whether the normal pull solenoid 5A fuse damage .

2) three roller gates SRU

3) three roller gates control board is damaged, or the control board when the solenoid is damaged, you must immediately notify our service department or authority for processing.

4) three roller gates limit board is damaged, or in direct sunlight, unplug the stopper plate 4P line, with open button test.

7.gates not reset gate

When the gates after the pedestrians do not immediately reset (continuous few individuals), after a period of delay in the locked gates before the state:

Detection method: First detection limit plate is not blocked when the red indicator lights up, otherwise the stopper plate damage;

Check the parameter settings P08 motherboard is set with memory;

8.directional board unchanged

When the gate voltage VDD and GND detection output on the motherboard (DC12V), otherwise damage to the motherboard; motherboard voltage normal directional board is damaged.

Appendix IV tripod turnstile wiring diagram

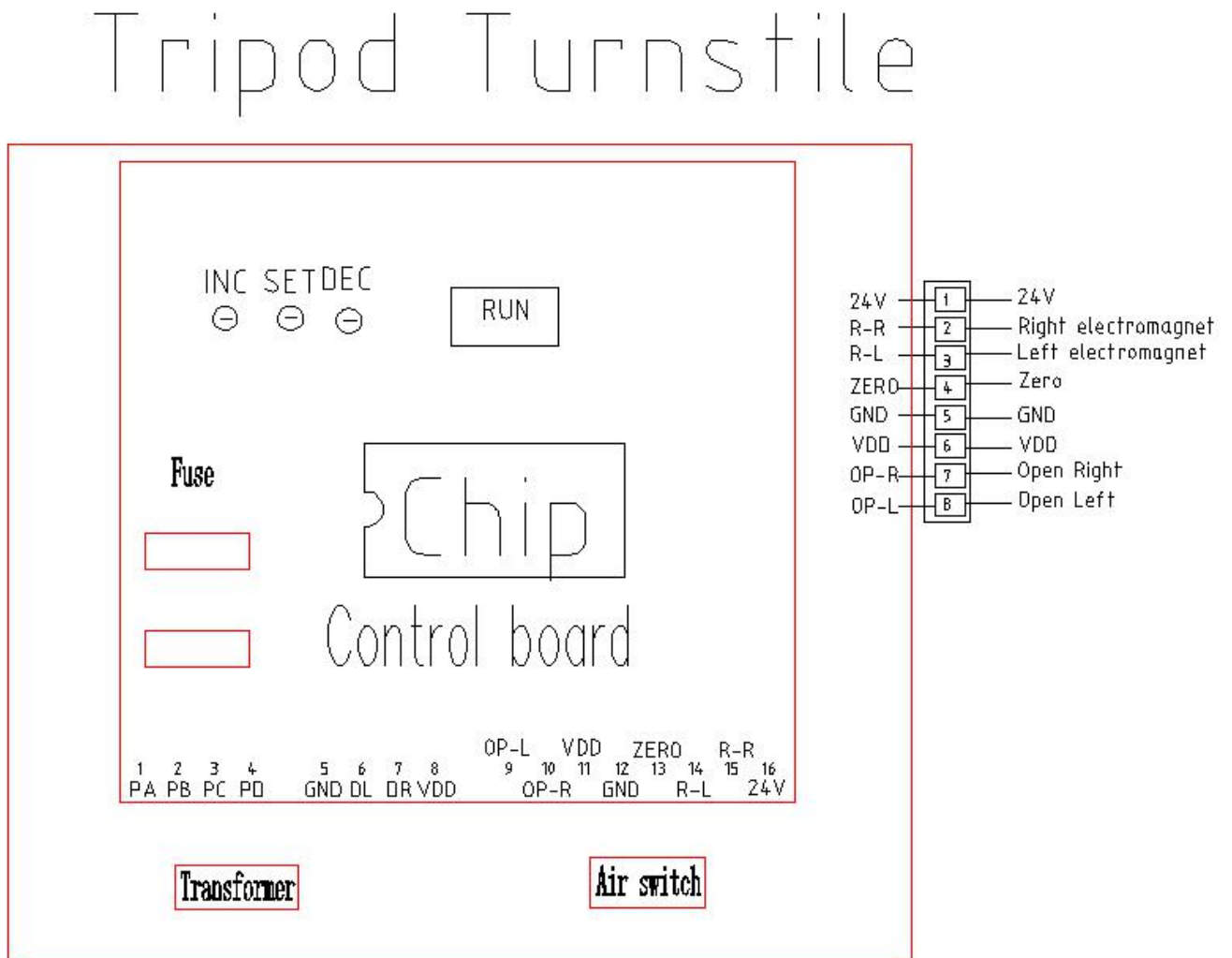

Note: Do not take the power supply from the control panel Patron other equipment, thereby causing damage to the circuit board is not covered under warranty.